

# Installation Instructions

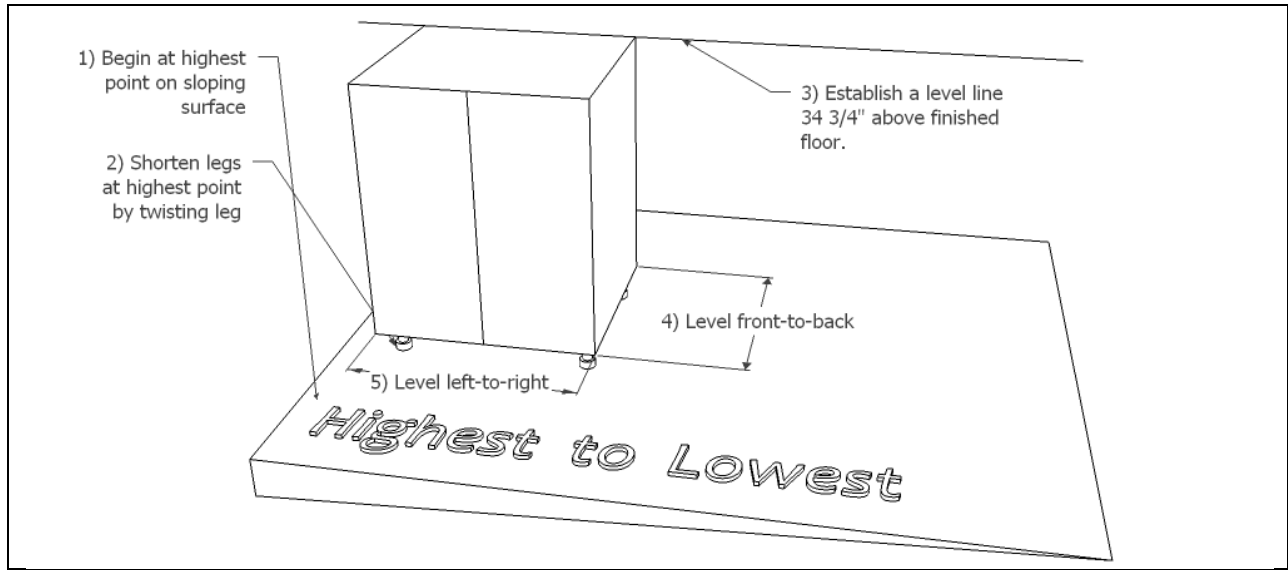

Cabinet installation is very simple and does not require previous cabinet installation experience or special knowledge of carpentry.

## Leveling the Cabinets



## Anchoring to Walls

Once leveled, fasten cabinets to walls using common hardware (not provided). For concrete block or stucco walls, stainless steel Tapcon® fasteners are recommended. Two fasteners per cabinet are recommended for base cabinets, four fasteners are recommended for wall cabinets.

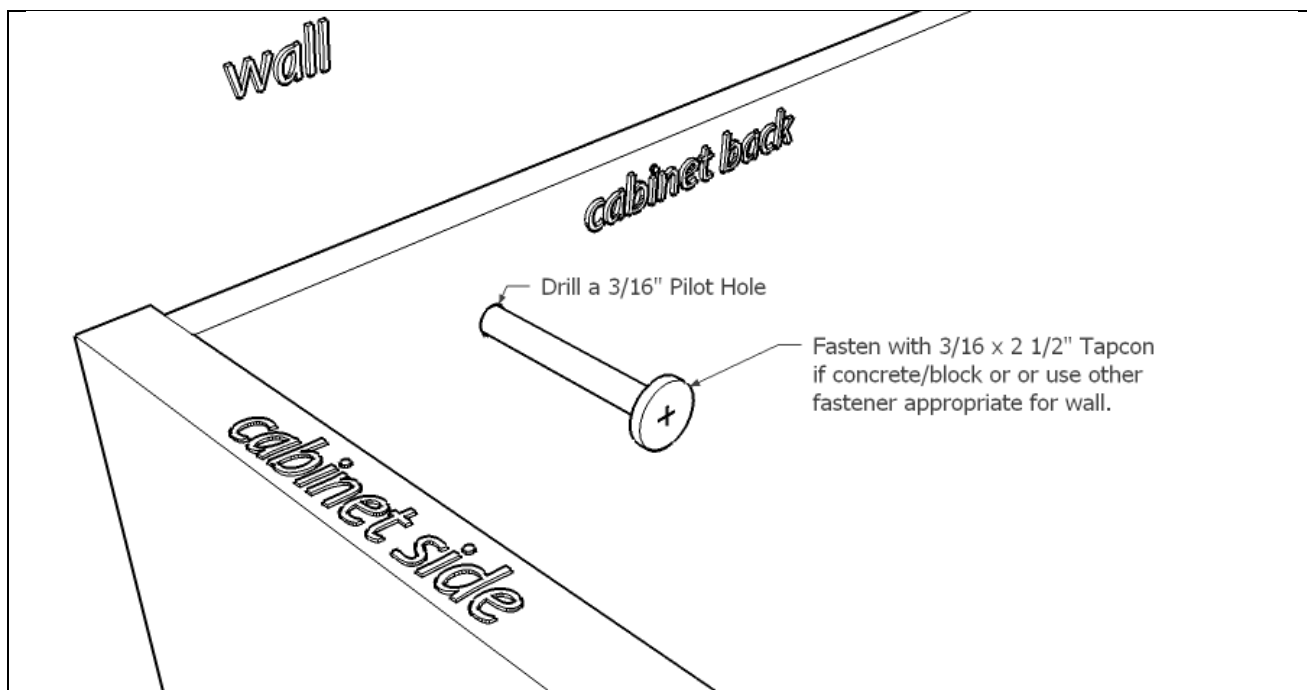

# Installation Instructions



## Fastening to Each Other

All cabinets and fillers have partially pre-drilled "universal fit" holes that are perfectly aligned for a precision fit. Finish drilling the holes of two adjoining cabinets using a 1/4" drill bit and then fasten the cabinets together using the provided hardware.

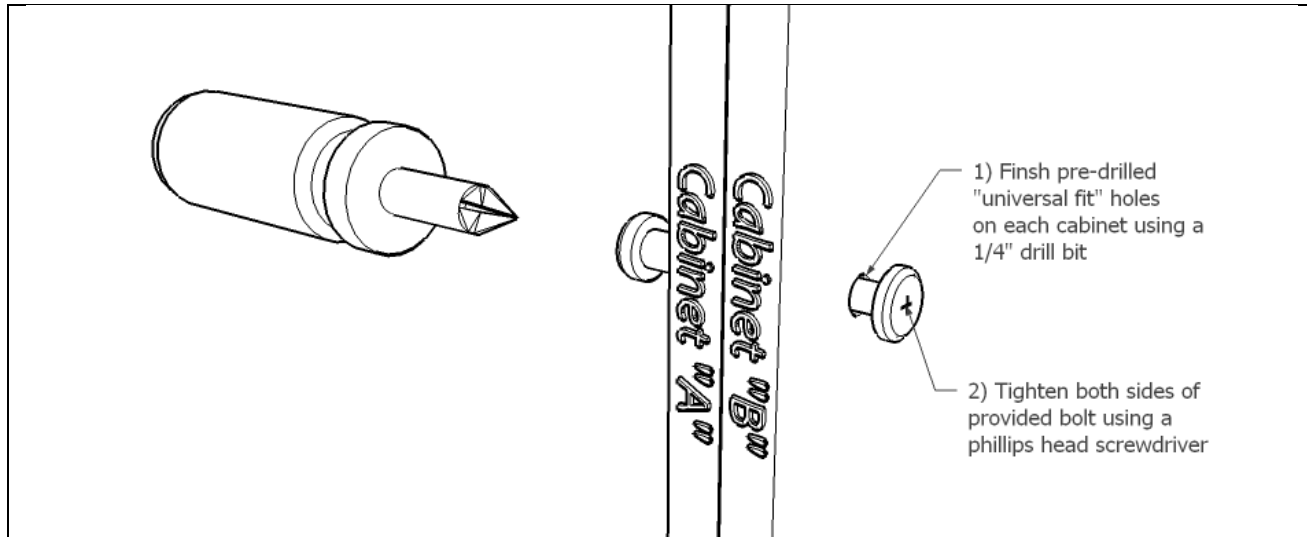

## Countertops

For a do-it-yourself project, a tile countertop is recommended. Professional countertop fabrication is recommended for granite, concrete, quartz (Silestone® or Zodiaq®), or solid-surface acrylic (Corian®) countertops. Cabinets feature special countertop installation aids.

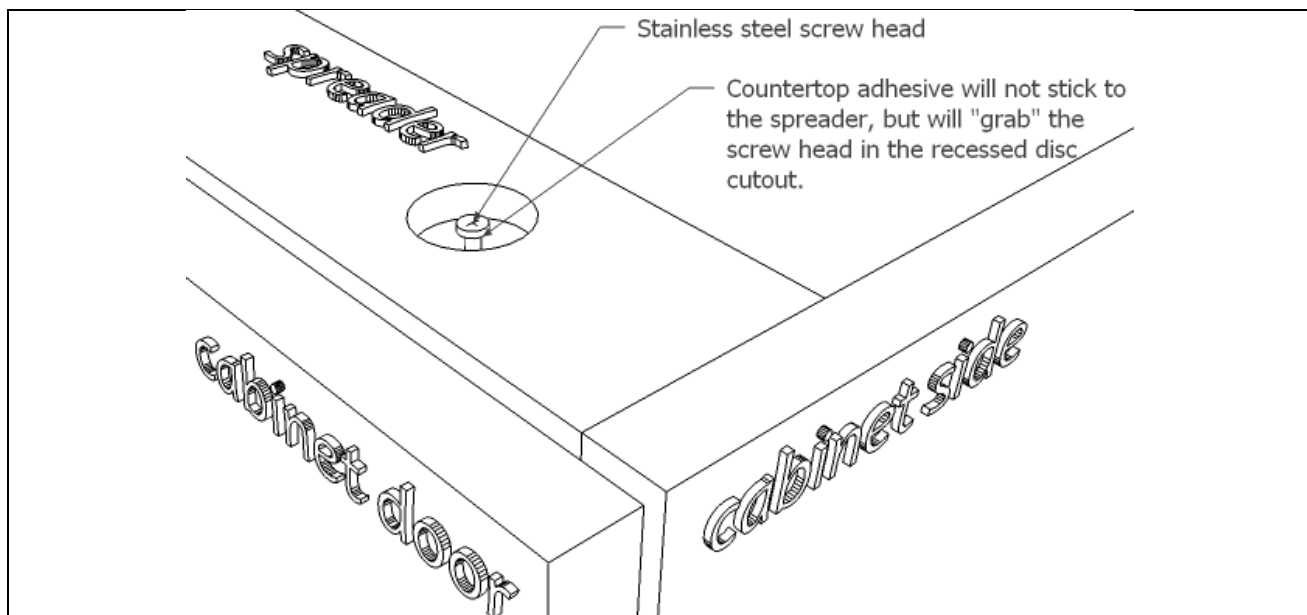

# Installation Instructions



## Countertops (continued)

Special mold & moisture resistant Nyloboard (TM) is used on the backspash and raised bar section. Adhesives can be used here to hold backspash and bar overhang sections. Corbels are also available for added bar countertop support.

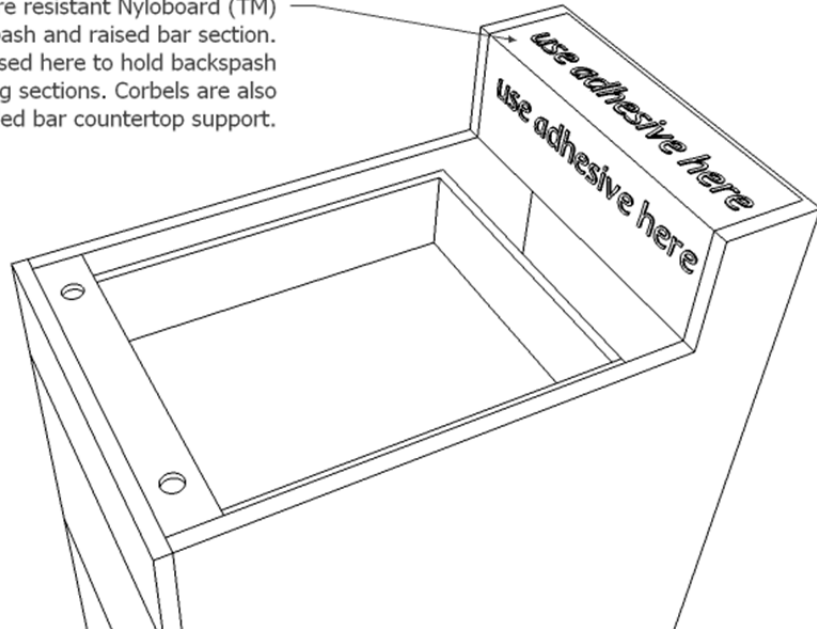

## Cutting through Cabinets

Holes can be easily cut in cabinet backs, sides, and bottoms for plumbing, gas lines, or electrical work using ordinary hand tools. **Cabinet corners and joints should not be cut as that will alter the structural integrity and strength of the cabinet.**

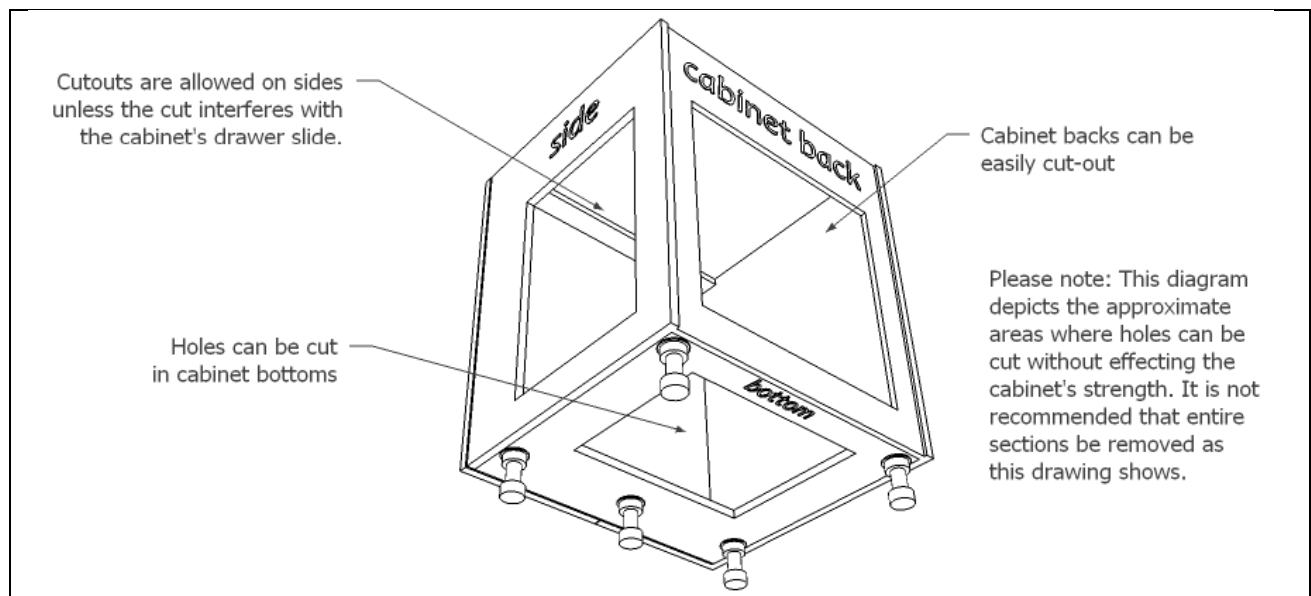

# Installation Instructions



## Toe Kick Panel

Once your cabinets are installed, optional toe kick panels can be added. For easiest cleaning and maintenance, you may consider omitting toe kick panels, allowing complete access underneath your outdoor kitchen for vacuuming or hose-washing. Toe kick panels can always be ordered and installed after the project is completed if you want to decide later if toe kick panels should be used.

